

Product Features

- Broadband Panel Antenna.
- Sealed Type N connector is mounted on the rear of the antenna for all weather durability.
- Unique combination of high gain and wide bandwidth make this antenna useful for broadband or multi-band microwave receivers and transmitters.
- Markets and applications include:
 - Law enforcement.
 - Surveillance.
 - ENG, UAV's and UGV's.

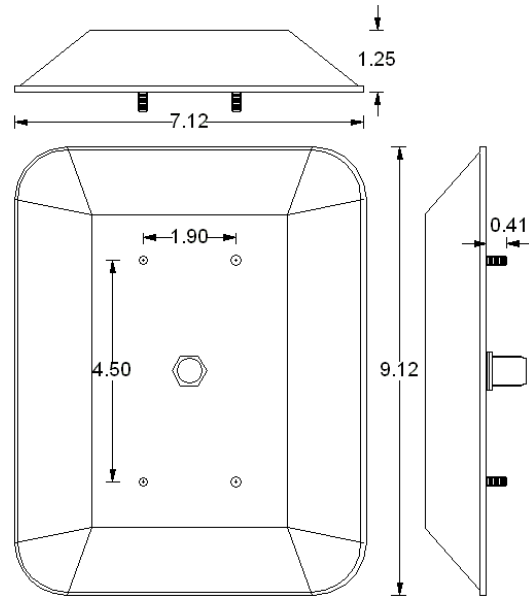

Dimensions in Inches

Specifications

SWA PN:	1009-001
Frequency:	1.7 – 2.5 GHz
Gain:	12 dBi
3 dBi Beamwidth	55 Azimuth
(typ)	32 Elevation
Polarity:	Vertical
VSWR:	≤ 1.5:1
Power:	100 Watts
Length:	9.19 inches
Width:	7.18 inches
Weight:	1 lb
Connector:	Type N(f)
Construction:	Al Ground Plane White Polycarbonate Radome
Mount:	4 each 10-32 Studs
Rating:	Outdoor

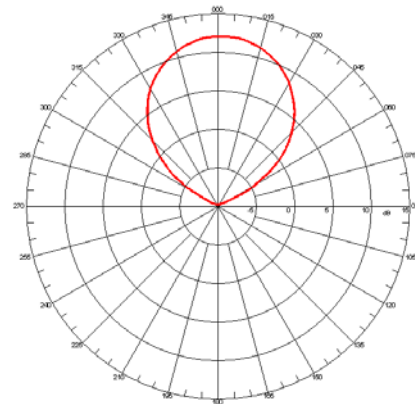

Azimuth

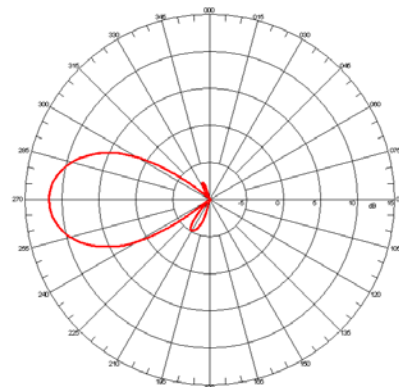

Elevation